

Clutch

EFAS 50

ref: 321.201.00

Specifications

Nominal torque	(Nm)	5
Minimal torque	(Nm)	0,05
Coil resistance - 20°C	(ohms)	24
Rated current DC	(A)	0,48
Rotor inertia	(kg.m ²)	37.10 ⁻⁶
Weight	(kg)	1,70
Heat dissipation continuous sustained	(W)*	50

* Heat dissipation is the mechanical power ($P = cw$) maximum allowable.

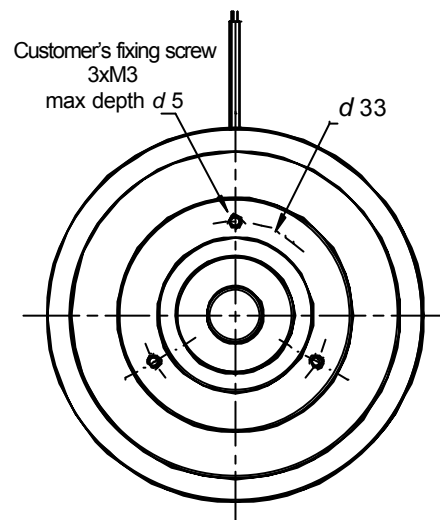
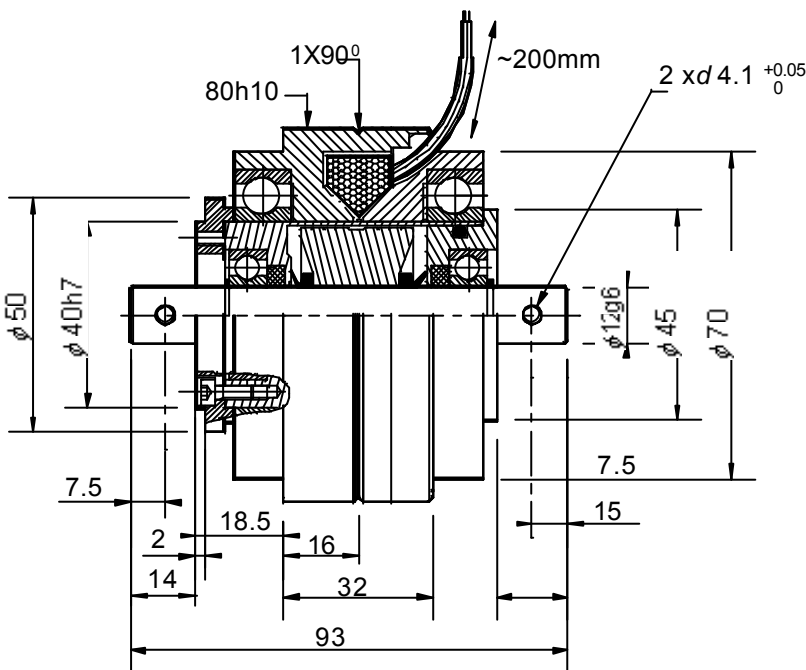
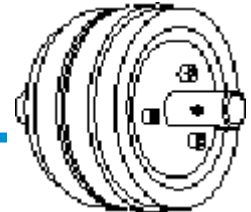

Utilization

- Mounting must be made without any stress.
Lubricated for life (other internal lubrication not allowed).
- Low DC current power supply for coil.
(See MEROBEL Electronic data sheets)
- The standard device is designed for horizontal shaft orientation, and a minimal speed of 60 RPM. Maximum speed is 3000 RPM (without exceeding the max. heat dissipation capability).
- For Engineering application, please contact our technical support.
- In normal use, the outside temperature of the device can increase up to 100°C, without damage.

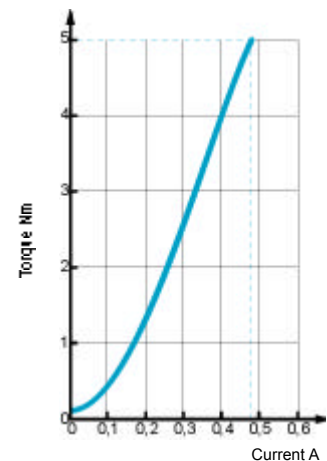

Safety

- If the device is to be used in dusty, humid or corrosive environment, special protection needs to be considered.

Maintenance

- Two procedures are available:
 - Full inhouse maintenance servicing: Please call +33 / 2 38 94 42 44
 - Spare parts or repair kits (depending on maintenance level):
 - Assembled drum ref: 806.585.01
 - Assembling inductor ref: 806.001.03
 - External ball bearings (x2) ref: 806.016.01
 - Pulley washer play ref: 807.096.01
 - In any case, our After Sales service is at your disposal.

Recommended mounting principles

